

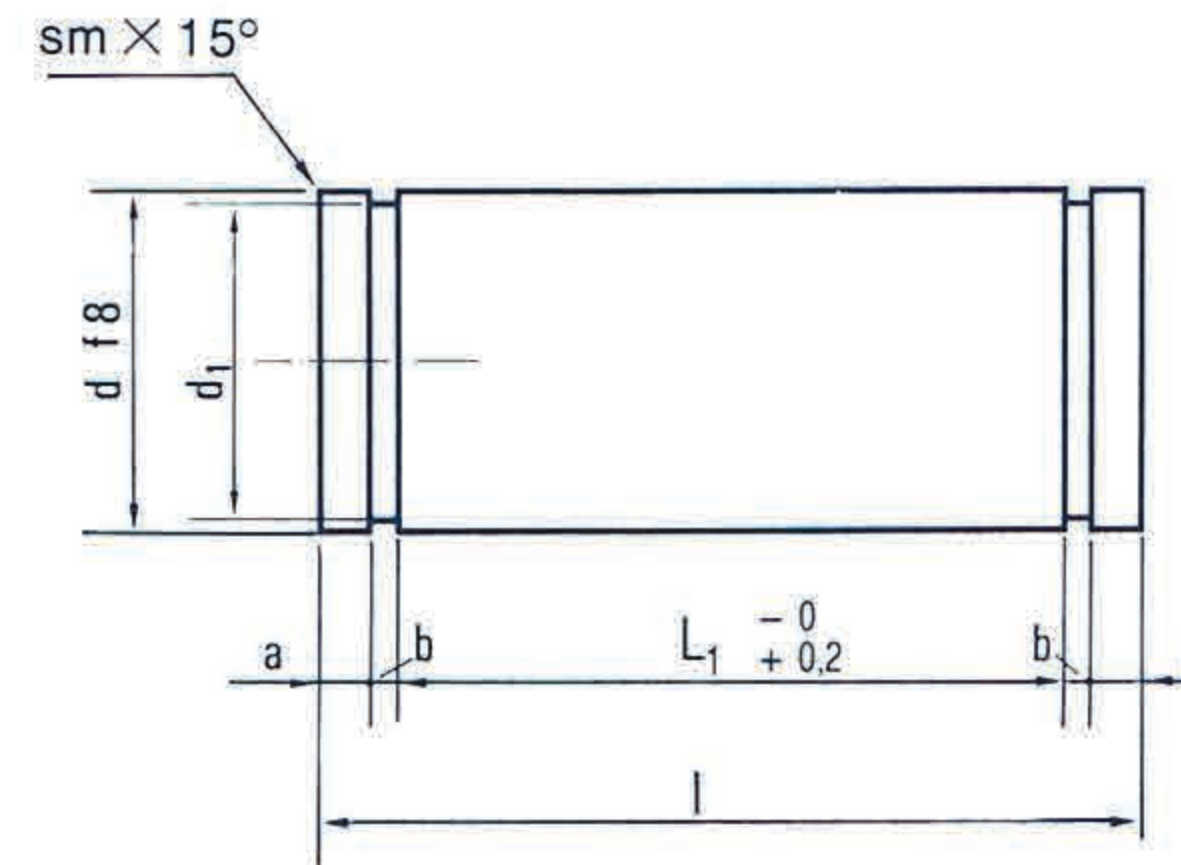

PERNI PER FORCELLE CETOP CLEVIS PINS - TOURILLON - BOLZEN

dimensioni
in millimetri

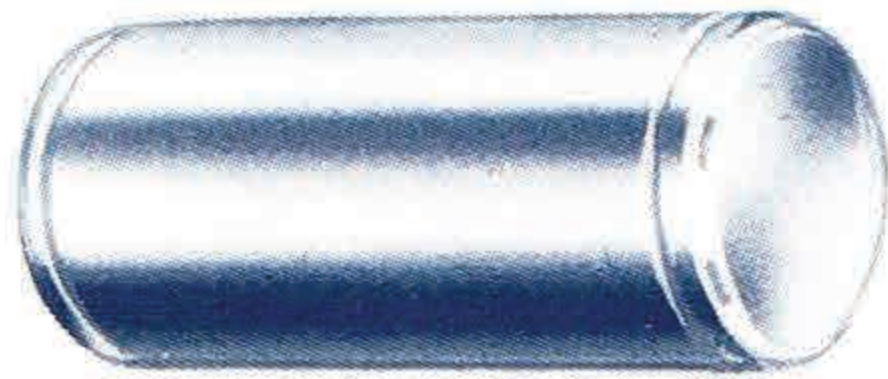

ACCIAIO - STEEL - ACIER - STAHL 9S Mn Pb 23 R 50 Kg./mm²

PERNI - CETOP d l	d ₁	l ₁	a	b	Usato per forcella CETOP	C O D I C E
10 x 25	9,6	20	1,5	1,2	M 10 x 1,25	P-CETOP 10
12 x 30	11,5	24	2	1,2	M 12 x 1,25	P-CETOP 12
16 x 39	15,2	32	2,4	1,2	M 16 x 1,5	P-CETOP 16
20 x 48	19	40	2,9	1,4	M 20 x 1,5	P-CETOP 20
25 x 60	23,9	50	3,7	1,4	M 24 x 2	P-CETOP 25
30 x 65	28,6	56	3	1,7	M 27 X 2	P-CETOP 27
35 x 84	33	70	5,4	1,7	M 36 x 2	P-CETOP 35